

**10 Cup Rice Cooker
Owner's Handbook**

CFXB35MB

contempo



IMPORTANT SAFETY INSTRUCTIONS	1	AFTER USE	10
CONTROLS AND FEATURES	4	CARE AND CLEANING	10
UNPACKING	5	SPECIFICATIONS.....	11
BEFORE YOU START	5	WARRANTY.....	12
Location for your rice cooker	5		
OPERATION.....	6		
First use	6		
What can I cook?.....	6		
Cooking times	6		
Cooking tips	6		
Cooking rice.....	7		
Steaming vegetables or fish	9		
Approximate steaming times for vegetables and fish	9		

Please keep your sales docket, including cash register receipt, in a safe place as the docket will prove the commencement of the period of this warranty. If you wish to make a claim specifically under this manufacturer's warranty, you will be required to provide proof of purchase, preferably your sales docket.

IMPORTANT SAFETY INSTRUCTIONS

Please read these instructions carefully before using the appliance for the first time.

- Always use the appliance from a power outlet of the same voltage (A.C. only) marked on the appliance.
- This appliance includes an earthed pin and must be used with a power outlet with earthed connection.
- Always turn the power off at the power outlet before you insert or remove a plug. Remove by grasping the plug - do not pull on the cord.
- Turn the power off and disconnect the plug from the mains outlet when the appliance is not in use and before cleaning.
- Do not use the appliance with an extension power board.
- If the supply cord is damaged, it must be replaced by the manufacturer, its service agent or similarly qualified persons in order to avoid a hazard.
- The appliance shall not be operated by means of an external timer or separate remote control system.
- Do not let the power cord of the appliance hang over the edge of a table or bench top or touch any hot surface.
- Do not place the appliance on or near a hot gas flame, electric element or on a heated oven. Do not place on top of any other appliance.
- For additional protection, it is recommended to use the appliance with a residual current device (safety switch) with a tripping current not exceeding 30mA in the power socket which supply power to the appliance.

IMPORTANT SAFETY INSTRUCTIONS

- Do not leave the power cord near the edge of a bench top where children may touch or pull it.
- Do not touch the surface of the appliance when in use as it is hot.
- This appliance is not intended for use by persons (including children) with reduced physical, sensory or mental capabilities, or lack of experience and knowledge, unless they have been given supervision or instruction concerning use of the appliance by a person responsible for their safety.
- Children should be supervised to ensure that they do not play with the appliance.
- Do not move the appliance while switched on or when it is still hot.
- Always operate the appliance on a flat, level surface.
- Do not use the appliance for any purpose other than its intended use.
- The appliance is for household use only and should not be used outdoors.
- Do not immerse the unit, cord, plug or base in water or any other liquid during use or for cleaning.
- Do not use accessories or attachments not supplied with the appliance.
- The steam vent is very hot when cooking, keep face and hands away from the lid and steam vent.

IMPORTANT SAFETY INSTRUCTIONS

- Use oven gloves or mitts to remove the lid and be careful to avoid escaping steam.
- Do not allow water from the lid to drip into the bottom of the base unit.
- Do not place food or liquid in the bottom of the base unit. Only the removable cooking bowl is designed to contain food or liquid.
- Never operate the rice cooker without food and liquid in the removable cooking bowl.
- Stop using any appliance with a damaged cord or plug or after the appliance malfunctions or is dropped or damaged in any manner. Return the appliance to the nearest authorised service facility for examination, repair or electrical or mechanical adjustment.
- Check there are no cracks in the lid before each use.
- Do not leave the rice cooker unattended when in use.
- For household and residential type environments use only.
 - Do not use in staff kitchen areas in shops, offices and other working environments;
 - Do not use in farm houses;
 - Do not use in hotels, motels.
 - Do not use in bed and breakfast type environments.

WARNING

- Avoid spillage on the plug or connector.
- The heating element surface is hot after use. Do not touch the part until it cools down.
- Use the appliance only as described in this manual. Any other use or misuse might lead to damage of the appliance, property or personal injury.

CONTROLS AND FEATURES

- | | |
|----------------------|---------------------------|
| 1. Cooker handles | 6. Lid |
| 2. Cooking indicator | 7. Steamer basket handles |
| 3. Warming indicator | 8. Steamer basket |
| 4. Start lever | 9. Cooking bowl |
| 5. Lid handle | |

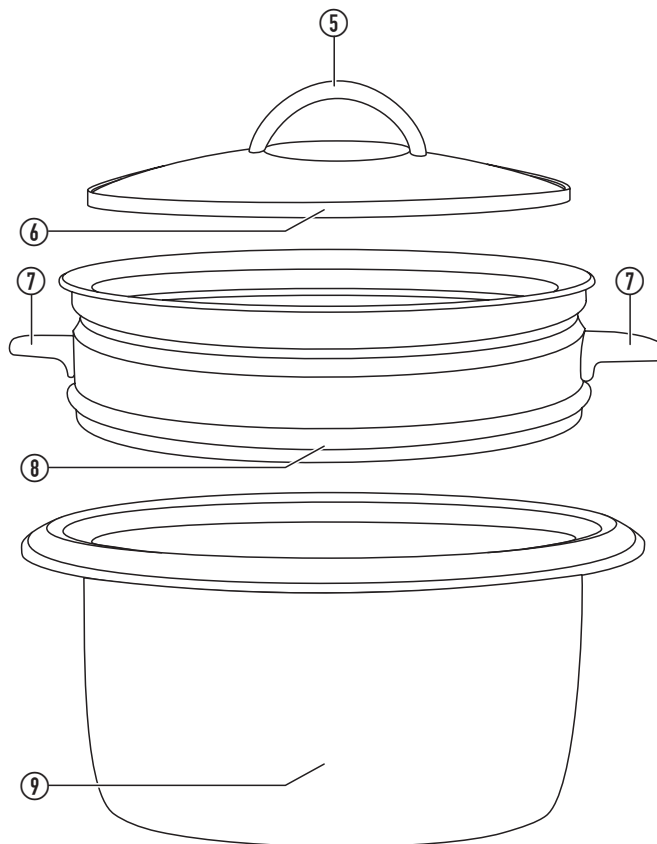
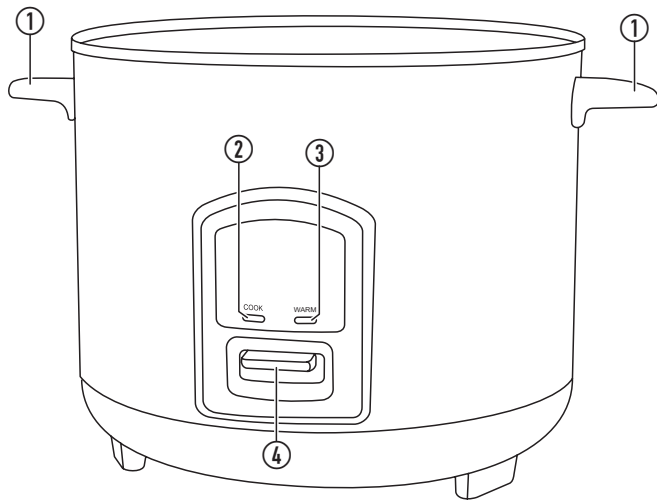

UNPACKING

Unpack the rice cooker and accessories from the carton.

Retain the carton and packing for future use. If you have to dispose of the carton and packing, please do so responsibly.

The carton should contain -

1 x CFXB35MB Rice cooker.

1 x Lid.

1 x Cooking bowl.

1 x Steamer basket.

1 x Measuring cup.

1 x Serving spoon.

1 x Owner's handbook.

BEFORE YOU START

Location for your rice cooker

- Choose a flat, stable location within reach of a mains power outlet.
- Clear away any items that may be damaged by the heat or steam from the rice cooker.
- Ensure that the rice cooker is located out of the reach of children when operational.
- Never place the rice cooker under a cupboard or overhanging surface. Exposure to steam during the cooking process may damage the surface.

OPERATION

First use

Before using your rice cooker for the first time you should ensure that it is thoroughly cleaned.

- Follow the instructions in the Cleaning and Care section to clean the cooking bowl, steamer basket, lid, measuring cup and serving spoon before they are first used.

Your rice cooker is now ready to use.

What can I cook?

Your rice cooker can cook any type of rice.

You can use the steamer basket to steam vegetables or fish.

Cooking times

Cooking times are best determined by experience, and will vary a lot depending on the type and quantity of rice you are cooking.

As a guide, white rice cooking times will normally be between 20 and 30 minutes, while brown rice and wild rice may take closer to 60 minutes.

Cooking tips

Always use the 160ml measuring cup supplied with the cooker for best results.

Always wash rice thoroughly before cooking it.

The keep warm feature is only intended to be used during a meal time. Never use it to keep rice warm for longer than this.

OPERATION

Cooking rice

- Use the table to find how much raw rice you need to cook and how much water you will need.
- Measure the rice into a bowl using the measuring cup supplied.
- Rinse the rice under slow running water until the water runs clear.
- Drain the rice and put it into the cooking bowl.
- Add fresh, cold water to the rice. Fill to the level marked on the inside of the cooking bowl or refer to the table for brown/wild rice.

Raw rice qty (cups)			
	Water level in cooking bowl for white rice (cups)		Cooked rice (cups)
		Water level in cooking bowl for brown/wild rice (cups)	
4	4	4.5 - 5	9
5	5	5.5 - 6	11
6	6	6.5-7	13
7	7	7.5-8	15
8	8	8.5-9	17
9	9	9.5-10	19
10	10	10.5-11	21

The maximum capacity of the cooking bowl is 10 cups. Never exceed this capacity.

OPERATION

- Place the cooking bowl into the rice cooker, rotating the cooking bowl slightly to settle it into place.

WARNING: Always ensure the external surface of the cooking bowl is dry before placing it in the rice cooker.

- Put the lid on the cooking bowl.
- Plug the power cord into a mains outlet.

The 'WARM' indicator will light.

- Press the start lever down.

The 'COOK' indicator will light and the rice will start to cook.

- When the rice is cooked, the start lever will lift, the 'COOK' indicator will go off and the 'WARM' indicator will light.

The rice is now cooked and keeping warm in the cooking bowl.

For best results, leave the rice to stand in the cooking bowl for ten minutes after the 'WARM' indicator lights.

- Disconnect the power cord before serving.
- Remove the lid with care to avoid hot steam.
- Transfer the cooked rice to a warm serving bowl or serve it directly from the cooker with the serving spoon.

CAUTION: The cooking bowl will be hot and should remain in the cooker until it cools.

NOTE: The bottom layer of rice may overcook and brown a little. This is normal and should be discarded.

OPERATION

Steaming vegetables or fish

- Clean and prepare the vegetables or fish ready for cooking.
- Place the cooking bowl into the cooker.
- Using the measuring cup, pour about $\frac{3}{4}$ cup of water into the cooking bowl.
- Place the steamer basket over the cooking bowl.
- Distribute the food evenly around the steamer basket.
- Put the lid on the steamer basket.
- Plug the power cord into a mains outlet.
- Press the start lever down.

The 'COOK' indicator will light and the food will start to cook.

- From time to time, carefully lift the lid and check how the food is cooking (the exact cooking time will vary depending on the type and quantity of food you are cooking).

NOTE: There is no automated timer to determine when steamed food is cooked.

- When the food is cooked, disconnect the power cord and lift off the steamer basket.
- Serve the food.

Approximate steaming times for vegetables and fish

All steamed with $\frac{3}{4}$ cup cold water or stock.

Approximate steaming times are in minutes.

Food	Qty	Preparation	Cook time
Fresh asparagus	140g	50mm pieces	13-15
Green beans	200g	50mm pieces	17-19
Beetroot	200g	Peeled, sliced	22-24
Broccoli	140g	Florets	15-17
Carrots	250g	Peeled, sliced	19-21
Cauliflower	250g	Florets	21-23
Celery	225g	50mm pieces	17-19
Sugar snap peas	225g	Trimmed, left whole	12-14
Peppers	1 large	Cut into strips	13-15
Potatoes	225g	Cut in wedges	21-23
Courgettes	225g	Slices	17-19
Salmon	170g	Fillet	24-26
Prawns	170g	Peeled, de-veined	14-16

AFTER USE

- Disconnect the cooker from mains power and allow it to cool completely.
- Follow the instructions in the Cleaning and Care section to clean the cooking bowl, lid, measuring jug and serving spoon.
- Dry the components completely and reassemble the cooking bowl and lid. The measuring cup and spoon can be stored in the cooking bowl.
- Loosely coil the cable and store the cooker safely out of reach of children.

CARE AND CLEANING

- Unplug the cooker and allow it to cool.
- Remove the cooking bowl and fill it with warm water. Allow it to soak for a while. If grains of rice are stuck to the base of the cooking bowl they must be removed. Never use sharp metal tools or abrasives to clean the cooking bowl as they will damage the non-stick surface. Soak, then use a nylon sponge or spatula to remove any remaining deposits.
- Wash the cooking bowl, lid, steamer basket, measuring cup and spoon with a mild detergent solution.
- Wipe the main body of the cooker with a damp cloth and dry well. Never immerse the cooker in water.

The rice cooker components are not dishwasher-safe. Always hand-wash them.

Never clean any component of the cooker with scourers, abrasive pads or chemicals.

SPECIFICATIONS

Power supply230 - 240V~, 50Hz

Power consumption.....643 - 700W

IMPORTANT: THIS APPLIANCE MUST BE EARTHED.



E285

WARRANTY

1. Our goods come with guarantees that cannot be excluded under the Australian Consumer Law. You are entitled to a replacement or refund for a major failure and for compensation for any other reasonably foreseeable loss or damage. You are also entitled to have the goods repaired or replaced if the goods fail to be of acceptable quality and the failure does not amount to a major failure. Where a failure does not amount to a major failure, BIG W is entitled to choose between providing you with a repair, replacement or refund. To obtain compensation, you would need to provide documentary evidence of the loss or damage suffered, and documentary evidence that such loss or damage was a reasonably foreseeable consequence of a failure by BIG W to comply with a consumer guarantee under the Australian Consumer Law. Such evidence may include photographs, statutory declarations, receipts or reports (eg from your doctor), depending on the loss or damage.
2. In addition to all rights and remedies to which you may be entitled under the Competition and Consumer Act 2010 (Commonwealth) and any other relevant legislation, the manufacturer warrants this product to be free from defects in materials or workmanship for a period of 24 months from the date of purchase.
3. In order to claim under this warranty you will need to bring the product to any BIG W store, along with proof of purchase (typically this will be a receipt). Any cost incurred by you in bringing the product to the service desk will be borne by you. We will then, at our option, either repair or replace the product, or refund your money and take back the product – in accordance with our Returns Policy, a copy of which is available at our return desk
4. Our liability under this manufacturer's warranty is subject to us being satisfied that a defect was caused by defective workmanship or materials, and was not caused by or substantially contributed to by other factors, or circumstances beyond our control, including (but not limited to) defective installation, maintenance or repair, alteration or modification of the product in a manner not recommended by the manufacturers or any neglect, misuse or excessive use.
5. The benefits conferred by this manufacturer's warranty are in addition to all rights and remedies conveyed by the Competition and Consumer Act 2010 (Commonwealth), and any other statutory rights to which you may already be entitled, and this warranty does not exclude, restrict or modify any such rights or remedies that are implied by law.
6. This warranty is provided by BIG W of 1 Woolworths Way, Bella Vista NSW 2153, Phone: 1300 244 999.

contempo

Made for Big W
1 Woolworths Way
Bella Vista NSW
2153 Australia

Made in China

CONTEMPO CFXB35MB V1